

DÆDALUS

Journal of the American Academy of Arts and Sciences

Myth, Symbol, and Culture

v *Preface*

- CLIFFORD GEERTZ 1 *Deep Play: Notes on the Balinese Cockfight*
- JAMES W. FERNANDEZ 39 *Persuasions and Performances: Of the
Beast in Every Body . . . And the
Metaphors of Everyman*
- MARY DOUGLAS 61 *Deciphering a Meal*
- FRANK E. AND 83 *Sketch for a Natural History of Paradise*
FRITZIE P. MANUEL
- JUDITH N. SHKLAR 129 *Subversive Genealogies*
- REUBEN A. BROWER 155 *Visual and Verbal Translation of Myth:
Neptune in Virgil, Rubens, Dryden*
- STEVEN MARCUS 183 *Language into Structure: Pickwick
Revisited*
- ROBERT M. ADAMS 203 *The Sense of Verification: Pragmatic
Commonplaces about Literary Criticism*
- 215 *Notes on Contributors*
- 217 *Recent Issues of Dædalus*

ADVISORY COMMITTEE
WINTER 1972: MYTH, SYMBOL, AND CULTURE

Robert M. Adams, Reuben A. Brower, Robbins Burling, Paul de Man, Mary Douglas, James W. Fernandez, Clifford Geertz, Hans Robert Jauss, Frank Kermode, Frank E. Manuel, Fritzie P. Manuel, Steven Marcus, George Miller, Harold Scheffler, Judith N. Shklar, Terrence Turner

Myth, Symbol, and Culture



Winter 1972: *Myth, Symbol, and Culture*
Issued as Vol. 101, No. 1, of the Proceedings of the American Academy of Arts and Sciences

Stephen R. Graubard, Editor of the Academy and of *Dædalus*;
Geno A. Ballotti, Managing Editor; Elizabeth Suttell, Manuscripts Editor; Bonnie J. Harris, Editorial Associate

Board of Editors

Raymond Aron, John E. Burchard, Clarence Faust, Karl von Frisch, Etienne Gilson, Gerald Holton, Clark Kerr, Archibald MacLeish, Talcott Parsons, Paul B. Sears, Harlow Shapley, George Wald

Editorial office: *Dædalus*, the Journal of the American Academy of Arts and Sciences, 7 Linden Street, Harvard University, Cambridge, Massachusetts 02138.

Subscription office: All subscription and single copy orders and change of address information should be addressed to the American Academy of Arts and Sciences, 280 Newton Street, Brookline, Massachusetts 02146.

Subscriptions: *Dædalus* is published quarterly. Subscription rate in the United States, \$8.00 a year; foreign, \$8.50. For prices of special issues, see listings at back of this volume.

Published by the American Academy of Arts and Sciences.

Printed in the United States of America. Printing office: 2901 Byrdhill Road, Richmond, Virginia. Library of Congress Catalog Card Number: 12-30299. Second-class postage paid at Boston, Massachusetts, and at additional mailing office. Copyright © 1971 by the American Academy of Arts and Sciences.

transformations that metaphoric associations undergo in various bodies of expressive culture, such as ritual. These are purportedly summed up for us in the sybelline Lévi-Strauss formula over which so much blood has been shed.

$$f_x(a) : f_y(b) :: f_x(b) : f_{a-1}(y)$$

This may be read in terms of our argument here as: The emotional movement or function (x) accomplished by some metaphor (a) is to the movement (y) accomplished by some metaphor (b) as the appropriation by metaphor (b) of its complementary movement (x) is to the transformation of a previous metaphor (a) into a significantly new movement ($a-1$) of a new metaphor (y) itself transformed from a previous movement. The only thing this can mean in terms of our discussion here is that movement can be transformed into metaphor and metaphor into movement within a given quality space.

An article on "The Performance of Ritual Metaphors," which attempts to give an account of metaphoric transformations in ritual, will appear in a collection of articles on *The Social Use of Metaphor*, edited by David Sapir for Cornell University Press.

19. W. V. O. Quine, *Word and Object* (Cambridge, Mass.: MIT Press, 1963), pp. 83ff. *Proceedings of the Institute of Radio Electronics*, 47 (November 1959), 1940-1959.

MARY DOUGLAS

Deciphering a Meal

IF LANGUAGE is a code, where is the precoded message? The question is phrased to expect the answer: nowhere. In these words a linguist is questioning a popular analogy.¹ But try it this way: if food is a code, where is the precoded message? Here, on the anthropologist's home ground, we are able to improve the posing of the question. A code affords a general set of possibilities for sending particular messages. If food is treated as a code, the messages it encodes will be found in the pattern of social relations being expressed. The message is about different degrees of hierarchy, inclusion and exclusion, boundaries and transactions across the boundaries. Like sex, the taking of food has a social component, as well as a biological one.² Food categories therefore encode social events. To say this is to echo Roland Barthes³ on the sartorial encoding of social events. His book, *Système de la mode*, is primarily about methodology, about code-breaking and code-making taken as a subject in itself. The next step for the development of this conceptual tool is to take up a particular series of social events and see how they are coded. This will involve a close understanding of a microscale social system. I shall therefore start the exercise by analyzing the main food categories used at a particular point in time in a particular social system, our home. The humble and trivial case will open the discussion of more exalted examples.

Sometimes at home, hoping to simplify the cooking, I ask, "Would you like to have just soup for supper tonight? I mean a good thick soup—instead of supper. It's late and you must be hungry. It won't take a minute to serve." Then an argument starts: "Let's have soup now, and supper when you are ready." "No no, to serve two meals would be more work. But if you like, why not start with the soup and fill up with pudding?" "Good heavens! What sort of a meal is that? A beginning and an end and no middle." "Oh, all right then, have the soup as it's there, and I'll do a Welsh rarebit as well." When they have eaten soup, Welsh rarebit, pudding, and cheese: "What a lot of plates. Why do you make such elaborate suppers?" They proceed to argue that by taking thought I could satisfy the full requirements of a meal with a single, copious dish. Several rounds of this conversation have given me a practical interest in the categories and

meanings of food. I needed to know what defines the category of a meal in our home.

The first source for enlightenment will obviously be Claude Lévi-Strauss's *The Raw and the Cooked* and the other volumes of his *Mythologiques*⁴ which discuss food categories and table manners. But this is only a beginning. He fails us in two major respects. First, he takes leave of the small-scale social relations which generate the codification and are sustained by it. Here and there his feet touch solid ground, but mostly he is orbiting in rarefied space where he expects to find universal food meanings common to all mankind. He is looking for a precoded, panhuman message in the language of food, and thus exposing himself to the criticism implicit in the quoted linguist's question. Second, he relies entirely on the resources of binary analysis. Therefore he affords no technique for assessing the relative value of the binary pairs that emerge in a local set of expressions. Worse than clumsy, his technical apparatus produces meanings which cannot be validated. Yea, or nay, he and Roman Jakobson may be right on the meanings in a sonnet of Baudelaire's.⁵ But even if the poet himself had been able to judge between theirs and Riffaterre's alternative interpretation of the same work⁶ and to say that one was closer to his thought than the other, he would be more likely to agree that all these meanings are there. This is fair for literary criticism, but when we are talking of grammar, coding, and the "science of the concrete,"⁷ it is not enough.

For analyzing the food categories used in a particular family the analysis must start with why those particular categories and not others are employed. We will discover the social boundaries which the food meanings encode by an approach which values the binary pairs according to their position in a series. Between breakfast and the last nightcap, the food of the day comes in an ordered pattern. Between Monday and Sunday, the food of the week is patterned again. Then there is the sequence of holidays and fast days through the year, to say nothing of life cycle feasts, birthdays, and weddings. In other words, the binary or other contrasts must be seen in their syntagmatic relations. The chain which links them together gives each element some of its meaning. Lévi-Strauss discusses the syntagmatic relation in his earlier book, *The Savage Mind*, but uses it only for the static analysis of classification systems (particularly of proper names). It is capable of a much more dynamic application to food categories, as Michael Halliday has shown. On the two axes of syntagm and paradigm, chain and choice, sequence and set, call it what you will, he has shown how food elements can be ranged until they are all accounted for either in grammatical terms, or down to the last lexical item.

Eating, like talking, is patterned activity, and the daily menu may be made to yield an analogy with linguistic form. Being an analogy, it is limited in relevance; its

purpose is to throw light on, and suggest problems of, the categories of grammar by relating these to an activity which is familiar and for much of which a terminology is ready to hand.

The presentation of a framework of categories for the description of eating might proceed as follows:

Units: Daily menu
Meal
Course
Helping
Mouthful

Unit: Daily Menu

Elements of primary structure	→ E, M, L, S ("early," "main," "light," "snack")
Primary structures	EML EMLS (conflated as EML(S))
Exponents of these elements (primary classes of unit "meal")	E: 1 (breakfast) M: 2 (dinner) L: 3 (no names available; see secondary) S: 4 (classes)
Secondary structures	EL _a S _a M EL _a M EML _b S _b EMS _a L _a
Exponents of secondary elements (systems of secondary classes of unit "meal")	L _a : 3.1 (lunch) L _b : 3.2 (high tea) L _c : 3.3 (supper) S _a : 4.1 (afternoon tea) S _b : 4.2 (nightcap)
System of sub-classes of unit "meal"	E: 1.1 (English breakfast) 1.2 (continental breakfast)

Passing to the rank of the "meal," we will follow through the class "dinner:"

Unit: Meal, Class: dinner

Elements of primary structure	→ F, S, M, W, Z ("first," "second," "main," "sweet," "savoury")
Primary structures	MW MWZ MZW FMW FMWZ FMZW FSMW FSMWZ FSMZW (conflated as (F(S)MW(Z)))
Exponents of these elements (primary classes of unit "course")	F: 1 (antipasta) S: 2 (fish) M: 3 (entrée) W: 4 (dessert) Z: 5 (cheese*)
Secondary structures	(various, involving secondary elements F _{a...d} , M _{a,b} , W _{a,c})
Exponents of secondary elements (systems of secondary classes of unit "course")	F _a : 1.1 (soup) F _b : 1.2 (hors d'oeuvres) F _c : 1.3 (fruit) F _d : 1.4 (fruit juice) M _a : 3.1 (meat dish) M _b : 3.2 (poultry dish) W _a : 4.1 (fruit*) W _b : 4.2 (pudding) W _c : 4.3 (ice cream*)

Systems of sub-classes of unit "course"	F _a : 1.11 (clear soup*) 1.12 (thick soup*)
	S: 2.01 (grilled fish*) 2.02 (fried fish*) 2.03 (poached fish*)
	W _b : 4.21 (streamed pudding*) 4.22 (milk pudding*)
Exponential systems operating in meal structure	F _c : grapefruit/melon F _d : grapefruit juice/pineapple juice/ tomato juice M _a : beef/mutton/pork M _b : chicken/turkey/duck/goose

At the rank of the "course," the primary class "entrée" has secondary classes "meat dish" and "poultry dish." Each of these two secondary classes carries a grammatical system whose terms are formal items. But this system accounts only for simple structures of the class "entrée," those made up of only one member of the unit "helping." The class "entrée" also displays compound structures, whose additional elements have as exponents the (various secondary classes of the) classes "cereal" and "vegetable." We will glance briefly at these:

<i>Unit: Course, Class: entrée</i>	
Elements of primary structure	J, T, A ("joint," "staple," "adjunct")
Primary structures	J JT JA JTA (conflated as J((T)(A)))
Exponents of these elements (primary classes of unit "helping")	J: 1 (flesh) T: 2 (cereal) A: 3 (vegetable)
Secondary structures	(various, involving—among others— secondary elements J _{a,b} , T _{a,b} , A _{a,b})
Exponents of secondary elements (systems of secondary classes of unit "helping")	J _a : 1.1 (meat) systems as at M in J _b : 1.2 (poultry) } meal structure T _a : 2.1 (potato) T _b : 2.2 (rice) A _a : 3.1 (green vegetable*) A _b : 3.2 (root vegetable*)

And so on, until everything is accounted for either in grammatical systems or in classes made up of lexical items (marked *). The presentation has proceeded down the rank scale, but shunting is presupposed throughout: there is mutual determination among all units, down to the gastronomic morpheme, the "mouthful."⁸

This advances considerably the analysis of our family eating patterns. First, it shows how long and tedious the exhaustive analysis would be, even to read. It would be more taxing to observe and record. Our model of ethnographic thoroughness for a microscopic example should not be less exact than that practiced by anthropologists working in exotic lands. In India social distinctions are invariably accompanied by distinctions in commensality and categories of edible and inedible foods. Louis Dumont's important work on Indian culture, *Homo Hierarchicus*, discusses the purity of food as an index of hierarchy. He gives praise to Adrian Mayer's detailed study of the relation between food categories and social categories in

a village in Central India.⁹ Here twenty-three castes group themselves according to the use of the same pipe, the provision of ordinary food for common meals, and the provision of food for feasts. Higher castes share the pipe with almost all castes except four. Between twelve and sixteen castes smoke together, though in some cases a different cloth must be placed between the pipe and the lips of the smoker. When it comes to their food, a subtler analysis is required. Castes which enjoy power in the village are not fussy about what they eat or from whom they receive it. Middle range castes are extraordinarily restrictive, both as to whom they will accept food from and what they will eat. Invited to family ceremonies by the more powerful and more ritually relaxed castes they puritanically insist on being given their share of the food raw and retire to cook it themselves in their own homes.¹⁰ If I were to follow this example and to include all transmission of food from our home my task would be greater. For certainly we too know situations in which drink is given to be consumed in the homes of the recipient. There are some kinds of service for which it seems that the only possible recognition is half or even a whole bottle of whiskey. With the high standards of the Indian research in mind, I try now to identify the relevant categories of food in our home.

The two major contrasted food categories are meals versus drinks. Both are social events. Outside these categories, of course, food can be taken for private nourishment. Then we speak only of the lexical item itself: "Have an apple. Get a glass of milk. Are there any sweets?" If likely to interfere with the next meal, such eating is disapproved. But no negative attitude condemns eating before drinks. This and other indices suggest that meals rank higher.

Meals contrast with drinks in the relation between solids and liquids. Meals are a mixture of solid foods accompanied by liquids. With drinks the reverse holds. A complex series of syntagmatic associations governs the elements in a meal, and connects the meals through the day. One can say: "It can't be lunchtime. I haven't had breakfast yet," and at breakfast itself cereals come before bacon and eggs. Meals in their sequence tend to be named. Drinks sometimes have named categories: "come for cocktails, come for coffee, come for tea," but many are not named events: "What about a drink? What shall we have?" There is no structuring of drinks into early, main, light. They are not invested with any necessity in their ordering. Nor is the event called drinks internally structured into first, second, main, sweet. On the contrary, it is approved to stick with the same kind of drink, and to count drinks at all is impolite. The judgment "It is too early for alcohol" would be both rare and likely to be contested. The same lack of structure is found in the solid foods accompanying drinks. They are usually cold, served in discrete units which can be eaten tidily with fingers. No order governs the choice of solids. When the children were small and tea was a meal, bread and butter preceded scones, scones preceded cake

and sweet biscuits. But now that the adult-child contrast no longer dominates in this family, tea has been demoted from a necessary place in the daily sequence of meals to an irregular appearance among weekend drinks and no rules govern the accompanying solids.

Meals properly require the use of at least one mouth-entering utensil per head, whereas drinks are limited to mouth-touching ones. A spoon on a saucer is for stirring, not sucking. Meals require a table, a seating order, restriction on movement and on alternative occupations. There is no question of knitting during a meal. Even at Sunday breakfast, reaching for the newspapers is a signal that the meal is over. The meal puts its frame on the gathering. The rules which hedge off and order one kind of social interaction are reflected in the rules which control the internal ordering of the meal itself. Drinks and their solids may all be sweet. But a meal is not a meal if it is all in the bland-sweet-sour dimensions. A meal incorporates a number of contrasts, hot and cold, bland and spiced, liquid and semi-liquid, and various textures. It also incorporates cereals, vegetables, and animal proteins. Criticism easily fastens on the ordering of these elements in a given case.

Obviously the meanings in our food system should be elucidated by much closer observation. I cut it short by drawing conclusions intuitively from the social categories which emerge. Drinks are for strangers, acquaintances, workmen, and family. Meals are for family, close friends, honored guests. The grand operator of the system is the line between intimacy and distance. Those we know at meals we also know at drinks. The meal expresses close friendship. Those we only know at drinks we know less intimately. So long as this boundary matters to us (and there is no reason to suppose it will always matter) the boundary between drinks and meals has meaning. There are smaller thresholds and half-way points. The entirely cold meal (since it omits a major contrast within a meal) would seem to be such a modifier. So those friends who have never had a hot meal in our home have presumably another threshold of intimacy to cross. The recent popularity of the barbecue and of more elaborately structured cocktail events which act as bridges between intimacy and distance suggests that our model of feeding categories is a common one. It can be drawn as in figure 1. Thus far we can go on the basis of binary oppositions and the number of classes and subclasses. But we are left with the general question which must be raised whenever a correspondence is found between a given social structure and the structure of symbols by which it is expressed, that is, the question of consciousness. Those who vehemently reject the possibility of a meal's being constituted by soup and pudding, or cake and fruit, are certainly not conscious that they are thereby sustaining a boundary between share-drinks and share-meals-too. They would be shocked at the very idea. It would be simplistic to trace the food categories direct to the social categories they embrace and leave

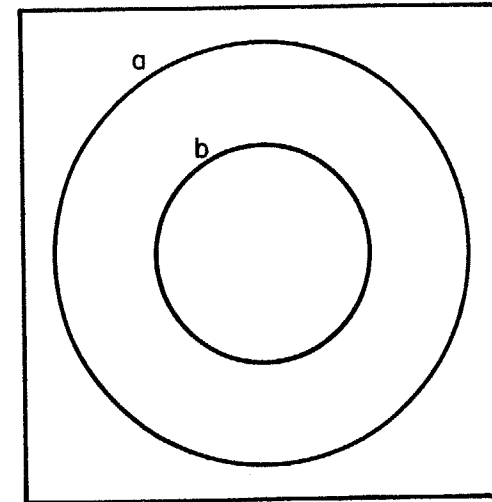

Figure 1. Social universe (a) share drinks; (b) share meals too.

it at figure 1. Evidently the external boundaries are only a small part of the meaning of the meal. Somewhere else in the family system some other cognitive activity is generating the internal structuring.

We can go much further toward discovering the intensity of meanings and their anchorage in social life by attending to the sequence of meals. For the week's menu has its climax at Sunday lunch. By contrasting the structure of Sunday lunch with weekday lunches a new principle emerges. Weekday lunches tend to have a tripartite structure, one element stressed accompanied by two or more unstressed elements, for example a main course and cold supporting dishes. But Sunday lunch has two main courses, each of which is patterned like the weekday lunch—say, first course, fish or meat (stressed) and two vegetables (unstressed), second course, pudding (stressed), cream and biscuits (unstressed). Christmas lunch has three courses, each on the same tripartite model. Here we stop and realize that the analogy may be read in the reverse sense. Meals are ordered in scale of importance and grandeur through the week and the year. The smallest, meanest meal metonymically figures the structure of the grandest, and each unit of the grand meal figures again the whole meal—or the meanest meal. The perspective created by these repetitive analogies invests the individual meal with additional meaning. Here we have the principle we were seeking, the intensifier of meaning, the selection principle. A meal stays in the category of meal only insofar as it carries this structure which allows the part to recall the whole. Hence the outcry against allowing the sequence of soup and pudding to be called a meal.

As to the social dimension, admission to even the simplest meal incorporates our guest unwittingly into the pattern of solid Sunday dinners,

Christmases, and the gamut of life cycle celebrations. Whereas the sharing of drinks (note the fluidity of the central item, the lack of structuring, the small, unsticky accompanying solids) expresses by contrast only too clearly the detachment and impermanence of simpler and less intimate social bonds.

Summing up, syntagmatic relations between meals reveal a restrictive patterning by which the meal is identified as such, graded as a minor or major event of its class, and then judged as a good or bad specimen of its kind. A system of repeated analogies upholds the process of recognition and grading. Thus we can broach the questions of interpretation which binary analysis by itself leaves untouched. The features which a single copious dish would need to display before qualifying as a meal in our home would be something like those of the famous chicken Marengo served to Napoleon after his victory over the Austrians.

Bonaparte, who, on the day of a battle, ate nothing until after it was over, had gone forward with his general staff and was a long way from his supply wagon. Seeing his enemies put to flight, he asked Dunand to prepare dinner for him. The master-chef at once sent men of the quartermaster's staff and ordnance in search of provisions. All they could find were three eggs, four tomatoes, six crayfish, a small hen, a little garlic, some oil and a saucepan . . . the dish was served on a tin plate, the chicken surrounded by the fried eggs and crayfish, with the sauce poured over it.¹¹

There must have been many more excellent meals following similar scavenging after the many victories of those campaigns. But only this one has become famous. In my opinion the reason is that it combines the traditional soup, fish, egg, and meat courses of a French celebratory feast all in a *plat unique*.

If I wish to serve anything worthy of the name of supper in one dish it must preserve the minimum structure of a meal. Vegetable soup so long as it had noodles and grated cheese would do, or poached eggs on toast with parsley. Now I know the formula. A proper meal is A (when A is the stressed main course) plus 2B (when B is an unstressed course). Both A and B contain each the same structure, in small, $a + 2b$, when a is the stressed item and b the unstressed item in a course. A weekday lunch is A; Sunday lunch is 2A; Christmas, Easter, and birthdays are $A + 2B$. Drinks by contrast are unstructured.

To understand the categories we have placed ourselves at the hub of a small world, a home and its neighborhood. The precoded message of the food categories is the boundary system of a series of social events. Our example made only oblique reference to costs in time and work to indicate the concerns involved. But unless the symbolic structure fits squarely to some demonstrable social consideration, the analysis has only begun. For the fit between the medium's symbolic boundaries and the boundaries between categories of people is its only possible validation. The fit may

be at different levels, but without being able to show some such matching, the analysis of symbols remains arbitrary and subjective.

The question that now arises is the degree to which a family uses symbolic structures which are available from the wider social system. Obviously this example reeks of the culture of a certain segment of the middle classes of London. The family's idea of what a meal should be is influenced by the Steak House and by the French *cuisine bourgeoise*. Yet herein is implied a synthesis of different traditions. The French version of the grand meal is dominated by the sequence of wines. The cheese platter is the divide between a mounting crescendo of individual savory dishes and a descending scale of sweet ones ending with coffee. Individual dishes in the French sequence can stand alone. Compare the melon course in a London restaurant and a Bordeaux restaurant. In the first, the half slice is expected to be dusted with powdered ginger and castor sugar ($a + 2b$) or decorated with a wedge of orange and a crystallized cherry ($a + 2b$). In the second, half a melon is served with no embellishment but its own perfume and juices. $A + 2B$ is obviously not a formula that our family invented, but one that is current in our social environment. It governs even the structure of the cocktail canapé. The latter, with its cereal base, its meat or cheese middle section, its sauce or pickle topping, and its mixture of colors, suggests a mock meal, a minute metonym of English middle-class meals in general. Whereas the French pattern is more like: $C^1 + B^1 + A^1/A^2 + B^2 + C^2$, when the cheese course divides A^1 (the main savory dish) from A^2 (the main sweet). It would be completely against the spirit of this essay to hazard a meaning for either structure in its quasi-environmental form. French families reaching out to the meal structure of their cultural environment develop it and interact with it according to their intentions. English families reach out and find another which they adapt to their own social purposes. Americans, Chinese, and others do likewise. Since these cultural environments afford an ambient stream of symbols, capable of differentiating and intensifying, but not anchored to a stable social base, we cannot proceed further to interpret them. At this point the analysis stops. But the problems which cannot be answered here, where the cultural universe is unbounded, can usefully be referred to a more closed environment.

To sum up, the meaning of a meal is found in a system of repeated analogies. Each meal carries something of the meaning of the other meals; each meal is a structured social event which structures others in its own image. The upper limit of its meaning is set by the range incorporated in the most important member of its series. The recognition which allows each member to be classed and graded with the others depends upon the structure common to them all. The cognitive energy which demands that a meal look like a meal and not like a drink is performing in the culinary medium the same exercise that it performs in language. First, it distin-

guishes order, bounds it, and separates it from disorder. Second, it uses economy in the means of expression by allowing only a limited number of structures. Third, it imposes a rank scale upon the repetition of structures. Fourth, the repeated formal analogies multiply the meanings that are carried down any one of them by the power of the most weighty. By these four methods the meanings are enriched. There is no single point in the rank scale, high or low, which provides the basic meaning or real meaning. Each exemplar has the meaning of its structure realized in the examples at other levels.

From coding we are led to a more appropriate comparison for the interpretation of a meal, that is, versification. To treat the meal as a poem requires a more serious example than I have used hitherto. I turn to the Jewish meal, governed by the Mosaic dietary rules. For Lu Chi, a third century Chinese poet, poetry traffics in some way between the world and mankind. The poet is one who "traps Heaven and Earth in a cage of form."¹² On these terms the common meal of the Israelites was a kind of classical poem. Of the Israelite table, too, it could be said that it enclosed boundless space. To quote Lu Chi again:

We enclose boundless space in a square-foot of paper;
We pour out deluge from the inch-space of the heart.¹³

But the analogy slows down at Lu Chi's last line. For at first glance it is not certain that the meal can be a tragic medium. The meal is a kind of poem, but by a very limited analogy. The cook may not be able to express the powerful things a poet can say.

*In Purity and Danger*¹⁴ I suggested a rational pattern for the Mosaic rejection of certain animal kinds. Ralph Bulmer has very justly reproached me for offering an animal taxonomy for the explanation of the Hebrew dietary laws. The principles I claimed to discern must remain, he argued, at a subjective and arbitrary level, unless they could take account of the multiple dimensions of thought and activity of the Hebrews concerned.¹⁵ S. J. Tambiah has made similarly effective criticisms of the same shortcoming in my approach.¹⁶ Both have provided from their own field work distinguished examples of how the task should be conducted. In another publication I hope to pay tribute to the importance of their research. But for the present purpose, I am happy to admit the force of their reproach. It was even against the whole spirit of my book to offer an account of an ordered system of thought which did not show the context of social relations in which the categories had meaning. Ralph Bulmer let me down gently by supposing that the ethnographic evidence concerning the ancient Hebrews was too meager. However, reflection on this new research and methodology has led me to reject that suggestion out of hand. We know plenty about the ancient Hebrews. The problem is how to recognize and relate what we know.

New Guinea and Thailand are far apart, in geography, in history, and in civilization. Their local fauna are entirely different. Surprisingly, these two analyses of animal classification have one thing in common. Each society projects on to the animal kingdom categories and values which correspond to their categories of marriageable persons. The social categories of descent and affinity dominate their natural categories. The good Thailand son-in-law knows his place and keeps to it: disordered, displaced sex is reprobated and the odium transferred to the domestic dog, symbol of dirt and promiscuity. From the dog to the otter, the transfer of odium is doubled in strength. This amphibian they class as wild, counterpart-dog. But instead of keeping to the wild domain it is apt to leave its sphere at flood time and to paddle about in their watery fields. The ideas they attach to incest are carried forward from the dog to the otter, the image of the utterly wrong son-in-law. For the Karam the social focus is upon the strained relations between affines and cousins. A wide range of manmade rules sustain the categories of a natural world which mirrors these anxieties. In the Thailand and Karam studies, a strong analogy between bed and board lies unmistakably beneath the system of classifying animals. The pattern of rules which categorize animals correspond in form to the patterns of rules governing human relations. Sexual and gastronomic consummation are made equivalents of one another by reasons of analogous restrictions applied to each. Looking back from these examples to the classifications of Leviticus we seek in vain a statement, however oblique, of a similar association between eating and sex. Only a very strong analogy between table and altar stares us in the face. On reflection, why should the Israelites have had a similar concern to associate sex with food? Unlike the other two examples, they had no rule requiring them to exchange their womenfolk. On the contrary, they were allowed to marry their parallel paternal first cousins. E. R. Leach has reminded us how strongly exogamy was disapproved at the top political level,¹⁷ and within each tribe of Israel endogamy was even enjoined (Deuteronomy 36). We must seek elsewhere for their dominant preoccupations. At this point I turn to the rules governing the common meal as prescribed in the Jewish religion. It is particularly interesting that these rules have remained the same over centuries. Therefore, if these categories express a relevance to social concerns we must expect those concerns to have remained in some form alive. The three rules about meat are: (1) the rejection of certain animal kinds as unfit for the table (Leviticus 11), (2) of those admitted as edible, the separation of the meat from blood before cooking (Leviticus 17:10), (3) the total separation of milk from meat, which involves the minute specialization of utensils (Exodus 23:19; 34:26; Deuteronomy 14:21).

I start with the classification of animals whose rationality I claim to have discerned. Diagrams will help to summarize the argument. First, animals are classified according to degrees of holiness (see figure 2). At

WATER			
AIR			
LAND			
	ALTAR	TABLE	ABOMINABLE

Figure 2. Degrees of holiness.

the bottom end of the scale some animals are abominable, **not to be touched or eaten**. Others are fit for the table, but not for the **altar**. None that are fit for the altar are not edible and vice versa, none that are not edible are sacrificeable. The criteria for this grading are coordinated for the three spheres of land, air, and water. Starting with the simplest, we find the sets as in figure 3.

Water creatures, to be fit for the table, must have fins and scales (Leviticus 13:9-12; Deuteronomy 14:19). Creeping swarming worms and snakes, if they go in the water or on the land, are not fit for the table (Deuteronomy 14:19; Leviticus 11:41-43). "The term swarming creatures

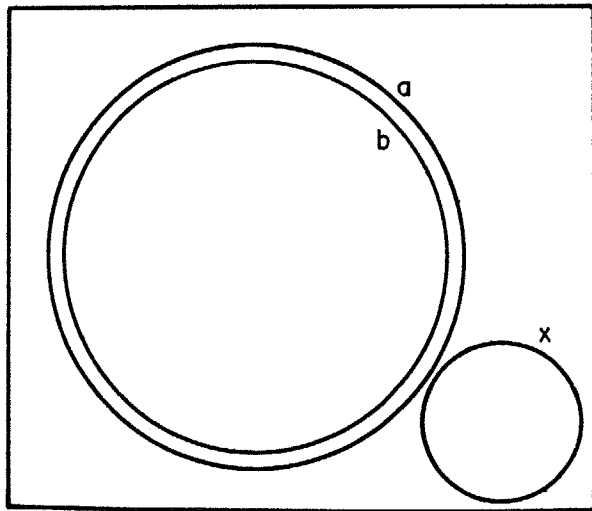

Figure 3. Denizens of the water (a) insufficient criteria for (b); (b) fit for table; (x) abominable: swarming.

(*shérec*) denotes living things which appear in swarms and is applied both to those which teem in the waters (Genesis 1:20; Leviticus 11:10) and to those which swarm on the ground, including the smaller land animals, reptiles and creeping insects."¹⁸ Nothing from this sphere is fit for the altar. The Hebrews only sanctified domesticated animals and these did not include fish. "When any one of you brings an offering to Jehovah, it shall be a domestic animal, taken either from the herd or from the flock" (Leviticus 1:2). But, Assyrians and others sacrificed wild beasts, as S. R. Driver and H. A. White point out.

Air creatures (see figure 4) are divided into more complex sets: set (a), those which fly and hop on the earth (Leviticus 11: 12), having wings and two legs, contains two subsets, one of which contains the named birds, abominable and not fit for the table, and the rest of the birds (b), fit for the table. From this latter subset a sub-subset (c) is drawn, which is suitable for the altar—turtledove and pigeon (Leviticus 14; 5:7-8) and the sparrow (Leviticus 14:49-53). Two separate sets of denizens of the air are abominable, untouchable creatures (f), which have the wrong number of limbs for their habitat, four legs instead of two (Leviticus 9:20), and (x), the swarming insects we have already noted in the water (Deuteronomy 14:19).

The largest class of land creatures (a) (see figure 5) walk or hop on the land with four legs. From this set of quadrupeds, those with parted hoofs and which chew the cud (b) are distinguished as fit for the table (Leviticus 11:3; Deuteronomy 14:4-6) and of this set a subset consists of the domesticated herds and flocks (c). Of these the first born (d) are to

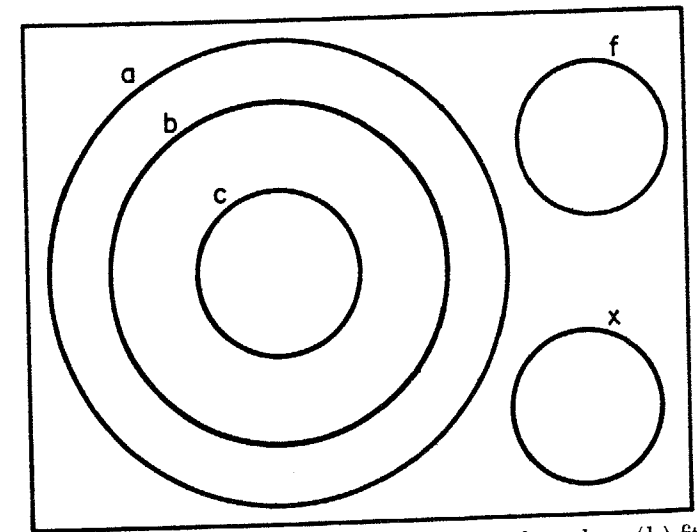

Figure 4. Denizens of the air (a) fly and hop: wings and two legs; (b) fit for table; (c) fit for altar; (f) abominable: insufficient criteria for (a); (x) abominable: swarming.

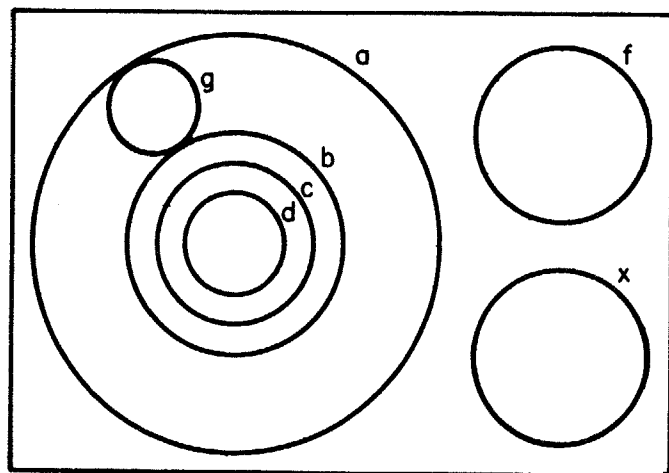

Figure 5. Denizens of the land (a) Walk or hop with four legs; (b) fit for table; (c) domestic herds and flocks; (d) fit for altar; (f) abominable: insufficient criteria for (a); (g) abominable: insufficient criteria for (b); (x) abominable: swarming.

be offered to the priests (Deuteronomy 24:33). Outside the set (b) which part the hoof and chew the cud are three sets of abominable beasts: (g) those which have either the one or the other but not both of the required physical features; (f) those with the wrong number of limbs, two hands instead of four legs (Leviticus 11:27 and 29:31); (x) those which crawl upon their bellies (Leviticus 11:41-44).

The isomorphism which thus appears between the different categories of animal classed as abominable helps us to interpret the meaning of abomination. Those creatures which inhabit a given range, water, air, or land, but do not show all the criteria for (a) or (b) in that range are abominable. The creeping, crawling, teeming creatures do not show criteria for allocation to any class, but cut across them all.

Here we have a very rigid classification. It assigns living creatures to one of three spheres, on a behavioral basis, and selects certain morphological criteria that are found most commonly in the animals inhabiting each sphere. It rejects creatures which are anomalous, whether in living between two spheres, or having defining features of members of another sphere, or lacking defining features. Any living being which falls outside this classification is not to be touched or eaten. To touch it is to be defiled and defilement forbids entry to the temple. Thus it can be summed up fairly by saying that anomalous creatures are unfit for altar and table. This is a peculiarity of the Mosaic code. In other societies anomaly is not always so treated. Indeed, in some, the anomalous creature is treated as the source of blessing and is specially fit for the altar (as the Lele pangolin), or as a noble beast, to be treated as an honorable adversary, as the

Karam treat the cassowary. Since in the Mosaic code every degree of holiness in animals has implications one way or the other for edibility, we must follow further the other rules classifying humans and animals. Again I summarize a long argument with diagrams. First, note that a category which divides some humans from others, also divides their animals from others. Israelites descended from Abraham and bound to God by the Covenant between God and Abraham are distinguished from all other peoples and similarly the rules which Israelites obey as part of the Covenant apply to their animals (see figure 6). The rule that the womb opener or first born is consecrated to divine service applies to firstlings of the flocks and herds (Exodus 22:29-30; Deuteronomy 24:23) and the rule of Sabbath observance is extended to work animals (Exodus 20:10). The analogy by which Israelites are to other humans as their livestock are to other quadrupeds develops by indefinite stages the analogy between altar and table.

Since Levites who are consecrated to the temple service represent the first born of all Israel (Numbers 3:12 and 40) there is an analogy between the animal and human firstlings. Among the Israelites, all of whom prosper through the Covenant and observance of the Law, some are necessarily unclean at any given time. No man or woman with issue of seed or blood, or with forbidden contact with an animal classed as unclean, or who has shed blood or been involved in the unsacralized killing of an animal (Leviticus 18), or who has sinned morally (Leviticus 20) can enter the temple. Nor can one with a blemish (Deuteronomy 23) enter the temple or eat the flesh of sacrifice or peace offerings (Leviticus 8:20). The Levites are selected by pure descent from all the Israelites. They represent the first born of Israel. They judge the cleanness and purify the uncleanness of Israelites (Leviticus 13, 14). Only Levites who are without bodily blemish (Leviticus 21:17-23) and without contact with death can enter the Holy of Holies. Thus we can present these rules as sets in figures 7 and 8. The analogy between humans and animals is very clear. So is the analogy created by these rules between the temple and the living body. Further analogies appear between the classification of animals according to holiness (figure 2) and the rules which set up the analogy of the holy temple with its holier and holier inner sanctuaries, and on the other hand between the temple's holiness and the body's purity and the

		Under the Covenant	
Human	Israelites	others	
Nonhuman	their livestock	others	

Figure 6. Analogy between humans and nonhumans.

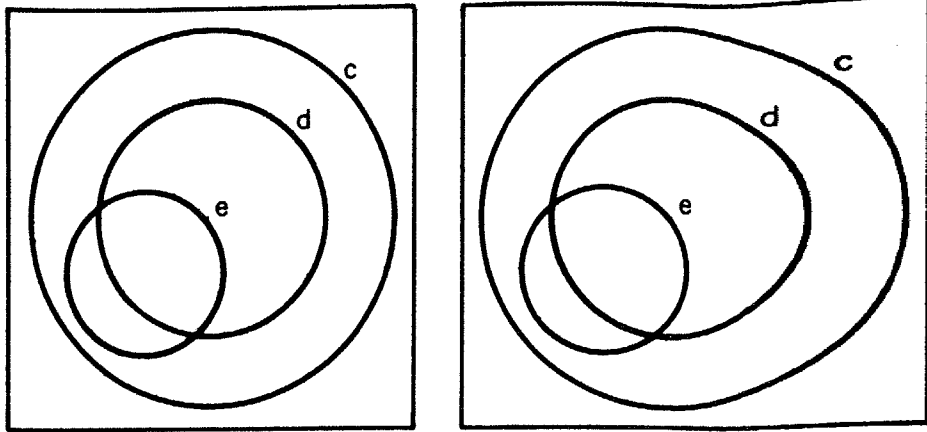

Figure 7. The Israelites (c) under the Covenant; (d) fit for temple sacrifice: no blemish; (e) consecrated to temple service, first born.

Figure 8. Their livestock (c) under the covenant; (d) fit for temple sacrifice: no blemish; (e) consecrated to temple service, first born.

capacity of each to be defiled by the self-same forms of impurity. This analogy is a living part of the Judeo-Christian tradition which has been unfaltering in its interpretation of New Testament allusions. The words of the Last Supper have their meaning from looking backward over the centuries in which the analogy had held good and forward to the future celebrations of that meal. "This is my body . . . this is my blood" (Luke 22:19-20; Mark 14:22-24; Matthew 26:26-28). Here the meal and the sacrificial victim, the table and the altar are made explicitly to stand for one another.

Lay these rules and their patternings in a straight perspective, each one looking forward and backward to all the others, and we get the same repetition of metonyms that we found to be the key to the full meaning of the categories of food in the home. By itself the body and its rules can carry the whole load of meanings that the temple can carry by itself with its rules. The overlap and repetitions are entirely consistent. What then are these meanings? Between the temple and the body we are in a maze of religious thought. What is its social counterpart? Turning back to my original analysis of the forbidden meats we are in a much better position to assess intensity and social relevance. For the metonymical patternings are too obvious to ignore. At every moment they are in chorus with a message about the value of purity and the rejection of impurity. At the level of a general taxonomy of living beings the purity in question is the purity of the categories. Creeping, swarming, teeming creatures abominably destroy the taxonomic boundaries. At the level of the individual living being impurity is the imperfect, broken, bleeding specimen. The sanctity of cognitive boundaries is made known by valuing the integrity of

the physical forms. The perfect physical specimens point to the perfectly bounded temple, altar, and sanctuary. And these in their turn point to the hard-won and hard-to-defend territorial boundaries of the Promised Land. This is not reductionism. We are not here reducing the dietary rules to any political concern. But we are showing how they are consistently celebrating a theme that has been celebrated in the temple cult and in the whole history of Israel since the first Covenant with Abraham and the first sacrifice of Noah.

Edmund Leach, in his analysis of the genealogy of Solomon, has reminded us of the political problems besetting a people who claim by pure descent and pure religion to own a territory that others held and others continually encroached upon.¹⁹ Israel is the boundary that all the other boundaries celebrate and that gives them their historic load of meaning. Remembering this, the orthodox meal is not difficult to interpret as a poem. The first rule, the rejection of certain animal kinds, we have mostly dealt with. But the identity of the list of named abominable birds is still a question. In the Mishnah it is written: "The characteristics of birds are not stated, but the Sages have said, every bird that seizes its prey (to tread or attack with claws) is unclean."²⁰ The idea that the unclean birds were predators, unclean because they were an image of human predation and homicide, so easily fits the later Hellenicizing interpretations that it has been suspect. According to the late Professor S. Hooke (in a personal communication), Professor R. S. Driver once tried out the idea that the Hebrew names were onomatopoeic of the screeches and calls of the birds. He diverted an assembly of learned divines with ingenious vocal exercises combining ornithology and Hebrew scholarship. I have not traced the record of this meeting. But following the method of analysis I have been using, it seems very likely that the traditional predatory idea is sufficient, considering its compatibility with the second rule governing the common meal.

According to the second rule, meat for the table must be drained of its blood. No man eats flesh with blood in it. Blood belongs to God alone, for life is in the blood. This rule relates the meal systematically to all the rules which exclude from the temple on grounds of contact with or responsibility for bloodshed. Since the animal kinds which defy the perfect classification of nature are defiling both as food and for entry to the temple, it is a structural repetition of the general analogy between body and temple to rule that the eating of blood defiles. Thus the birds and beasts which eat carrion (undrained of blood) are likely by the same reasoning to be defiling. In my analysis, the Mishnah's identifying the unclean birds as predators is convincing.

Here we come to a watershed between two kinds of defilement. When the classifications of any metaphysical scheme are imposed on nature, there are several points where it does not fit. So long as the classifications

remain in pure metaphysics and are not expected to bite into daily life in the form of rules of behavior, no problem arises. But if the unity of Godhead is to be related to the unity of Israel and made into a rule of life, the difficulties start. First there are the creatures whose behavior defies the rigid classification. It is relatively easy to deal with them by rejection and avoidance. Second there are the difficulties that arise from our biological condition. It is all very well to worship the holiness of God in the perfection of his creation. But the Israelites must be nourished and must reproduce. It is impossible for a pastoral people to eat their flocks and herds without damaging the bodily completeness they respect. It is impossible to renew Israel without emission of blood and sexual fluids. These problems are met sometimes by avoidance and sometimes by consecration to the temple. The draining of blood from meat is a ritual act which figures the bloody sacrifice at the altar. Meat is thus transformed from a living creature into a food item.

As to the third rule, the separation of meat and milk, it honors the procreative functions. The analogy between human and animal parturition is always implied, as the Mishnah shows in its comment on the edibility of the afterbirth found in the slaughtered dam: if the afterbirth had emerged in part, it is forbidden as food; "it is a token of young in a woman and a token of young in a beast."²¹ Likewise this third rule honors the Hebrew mother and her initial unity with her offspring.

In conclusion I return to the researches of Tambiah and Bulmer. In each case a concern with sexual relations, approved or disapproved, is reflected on to the Thailand and Karam animal classifications. In the case of Israel the dominant concern would seem to be with the integrity of territorial boundaries. But Edmund Leach has pointed out how over and over again they were concerned with the threat to Israel's holy calling from marriages with outsiders. Foreign husbands and foreign wives led to false gods and political defections. So sex is not omitted from the meanings in the common meal. But the question is different. In the other cases the problems arose from rules about exchanging women. In this case the concern is to insist on not exchanging women.

Perhaps I can now suggest an answer to Ralph Bulmer's question about the abhorrence of the pig. "Dr. Douglas tells us that the pig was an unclean beast to the Hebrew quite simply because it was a taxonomic anomaly, literally as the Old Testament says, because like the normal domestic animals it has a cloven hoof, whereas unlike other cloven-footed beasts, it does not chew the cud. And she pours a certain amount of scorn on the commentators of the last 2,000 years who have taken alternative views and drawn attention to the creature's feeding habits, etc." Dr. Bulmer would be tempted to reverse the argument and to say that the other animals are prohibited as part of an elaborate exercise for rationalizing "the prohibition of a beast for which there were probably multiple rea-

sons for avoiding. It would seem equally fair, on the limited evidence available, to argue that the pig was accorded anomalous taxonomic status because it was unclean as to argue that it was unclean because of its anomalous taxonomic status."²² On more mature reflection, and with the help of his own research, I can now see that the pig to the Israelites could have had a special taxonomic status equivalent to that of the otter in Thailand. It carries the odium of multiple pollution. First it pollutes because it defies the classification of ungulates. Second, it pollutes because it eats carrion. Third, it pollutes because it is reared as food (and presumably as prime pork) by non-Israelites. An Israelite who betrothed a foreigner might have been liable to be offered a feast of pork. By these stages it comes plausibly to represent the utterly disapproved form of sexual mating and to carry all the odium that this implies. We now can trace a general analogy between the food rules and the other rules against mixtures: "Thou shalt not make thy cattle to gender with beasts of any other kind" (Leviticus 19:19). "Thou shalt not copulate with any beast" (Leviticus 18:23). The common meal, decoded, as much as any poem, summarizes a stern, tragic religion.

We are left the question of why, when so much else had been forgotten²³ about the rules of purification and their meaning, the three rules governing the Jewish meal have persisted. What meanings do they still encode, unmoored as they partly are from their original social context? It would seem that whenever a people are aware of encroachment and danger, dietary rules controlling what goes into the body would serve as a vivid analogy of the corpus of their cultural categories at risk. But here I am, contrary to my own strictures, suggesting a universal meaning, free of particular social context, one which is likely to make sense whenever the same situation is perceived. We have come full-circle to figure 1, with its two concentric circles. The outside boundary is weak, the inner one strong. Right through the diagrams summarizing the Mosaic dietary rules the focus was upon the integrity of the boundary at (b). Abominations of the water are those finless and scaleless creatures which lie outside that boundary. Abominations of the air appear less clearly in this light because the unidentified forbidden birds had to be shown as the widest circle from which the edible selection is drawn. If it be granted that they are predators, then they can be shown as a small subset in the unlisted set, that is as denizens of the air not fit for table because they eat blood. They would then be seen to threaten the boundary at (b) in the same explicit way as among the denizens of the land the circle (g) threatens it. We should therefore not conclude this essay without saying something more positive about what this boundary encloses. In the one case it divides edible from inedible. But it is more than a negative barrier of exclusion. In all the cases we have seen, it bounds the area of structured relations. Within that area rules apply. Outside it, anything goes. Following the argument we

have established by which each level of meaning realizes the others which share a common structure, we can fairly say that the ordered system which is a meal represents all the ordered systems associated with it. Hence the strong arousal power of a threat to weaken or confuse that category. To take our analysis of the culinary medium further we should study what the poets say about the disciplines that they adopt. A passage from Roy Fuller's lectures helps to explain the flash of recognition and confidence which welcomes an ordered pattern. He is quoting Allen Tate, who said: "Formal versification is the primary structure of poetic order, the assurance to the reader and to the poet himself that the poet is in control of the disorder both outside him and within his own mind."²⁴

The rules of the menu are not in themselves more or less trivial than the rules of verse to which a poet submits.

I am grateful to Professor Basil Bernstein and to Professor M. A. K. Halliday for valuable suggestions and for criticisms, some of which I have not been able to meet. My thanks are due to my son James for working out the Venn diagrams used in this article.

REFERENCES

1. Michael A. K. Halliday, "Categories of the Theory of Grammar," *Word, Journal of the Linguistic Circle of New York*, 17 (1961), 241-291.
2. The continuing discussion between anthropologists on the relation between biological and social facts in the understanding of kinship categories is fully relevant to the understanding of food categories.
3. Roland Barthes, *Système de la mode* (Paris: Editions Seuil, 1967).
4. Claude Lévi-Strauss, *The Raw and the Cooked: Introduction to a Science of Mythology*, I (London: Jonathan Cape, 1970). The whole series in French is *Mythologiques*: I. *Le Cru et le cuit*, II. *Du Miel aux cendres*, III. *L'Origine des manières de table* (Paris: Plon, 1964-1968).
5. Roman Jakobson and Claude Lévi-Strauss, "Les Chats de Charles Baudelaire," *L'Homme*, 2 (1962), 5-21.
6. Michael Riffaterre, "Describing Poetic Structures: Two Approaches to Baudelaire's *Les Chats*," *Structuralism*, Yale French Studies 36 and 37 (1967).
7. Claude Lévi-Strauss, *The Savage Mind* (London: Heidenfeld and Nicholson, 1966; Chicago: University of Chicago Press, 1962, 1966).
8. Halliday, "Categories of the Theory of Grammar," pp. 277-279.
9. Adrian C. Mayer, *Caste and Kinship in Central India: A Village and Its Region* (London: Routledge, 1960).
10. Louis Dumont, *Homo Hierarchicus: The Caste System and Its Implications*, trans. M. Sainsbury (London: Weidenfeld & Nicholson, 1970; French ed., Gallimard, 1966), pp. 86-89.

11. See under "Marengo," *Larousse Gastronomique* (Hamlyn, 1961).
12. A. MacLeish, *Poetry and Experience* (London: Bodley Head, 1960), p. 4.
13. *Ibid.*
14. Mary Douglas, *Purity and Danger: An Analysis of Concepts of Pollution and Taboo* (London: Routledge, 1966).
15. Ralph Bulmer, "Why Is the Cassowary Not a Bird? A Problem of Zoological Taxonomy Among the Karam of the New Guinea Highlands," *Man*, new ser., 2 (1967), 5-25.
16. S. J. Tambiah, "Animals Are Good to Think and Good to Prohibit," *Ethnology*, 7 (1969), 423-459.
17. E. R. Leach, "The Legitimacy of Solomon," *Genesis as Myth and Other Essays* (London: Jonathan Cape, 1969).
18. S. R. Driver and H. A. White, *The Polychrome Bible, Leviticus*, v.l.fn. 13.
19. Leach, "Legitimacy of Solomon."
20. H. Danby, trans, *The Mishnah* (London: Oxford University Press, 1933), p. 324.
21. *Ibid.*, p. 520.
22. Bulmer, "Why Is the Cassowary Not a Bird?" p. 21.
23. Moses Maimonides, *Guide for the Perplexed*, trans. M. Friedlander (London: Routledge, 1904; first ed., 1881).
24. Roy Fuller, *Owls and Artificers: Oxford Lectures on Poetry* (London: Andre Deutsch, 1971), p. 64.